

**RAIN WATER OUTLET IN
SUMP OR GUTTER**

CT-5-0004
No Scale - 11/09

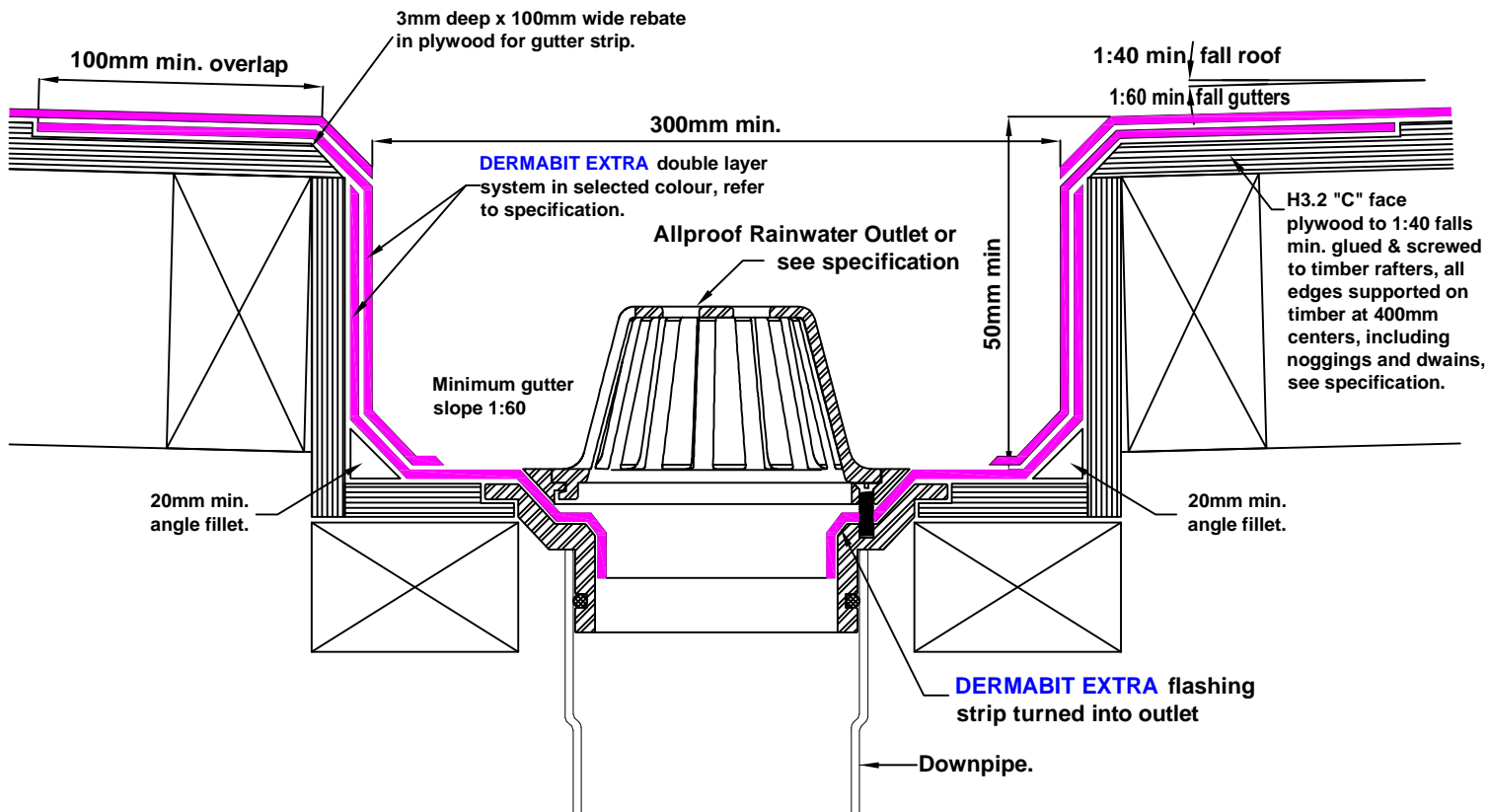

The information and data contained herein are believed to be accurate and reliable. This information does not constitute a warranty and should be used in conjunction with the project specification document and Quality Assurance manual supplied by Allco Agencies Ltd. Please contact Allco Agencies Ltd with any questions or deviations from this information. Allco Agencies Ltd 2006
"Reproduced from the Code of Practice for Torch-on Membrane Systems, the Membrane Group New Zealand, Inc"



For Technical Advice Contact:
(09) 448-1185 or
info@aliko.co.nz